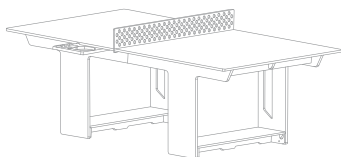


# LEDGE®

## Table Tennis Assembly Guide



### ▲ BEFORE YOU BEGIN

Unpack and lay all Table Tennis pieces flat on a padded surface to avoid scratching or damaging them. Locate and count all parts before discarding any packaging.

### PARTS



**8**  
**SMALL**  
**KEYS**



**4**  
**MEDIUM**  
**KEYS**



**22**  
**BIG**  
**KEYS**



**4 - 3/8"**  
**SCREWS**



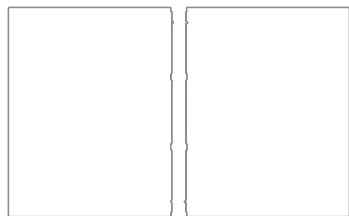
**32 - 5/8"**  
**SCREWS**



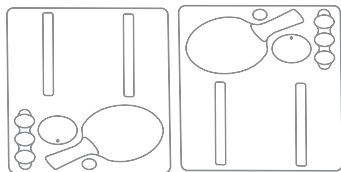
**35 - 1"**  
**SCREWS**



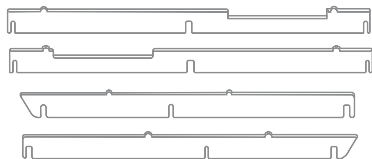
**1 SCREW**  
**DRIVER**



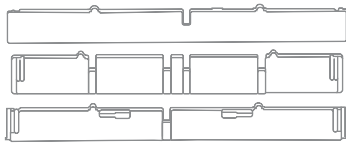
**2 COVERS TOP**



**2 DRAWERS**

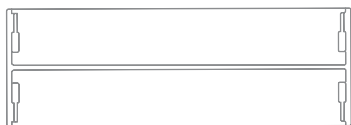


**4 LONG CROSSBARS**

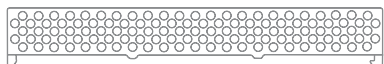


**3 SHORT CROSSBARS**

## PARTS (CONTINUED)



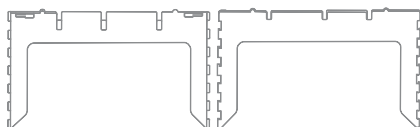
**2 SHELVES**



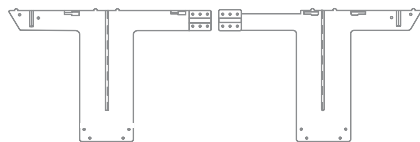
**1 NET**



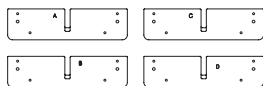
**2 BOTTOM  
CROSS BARS**



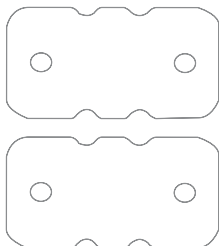
**2 BRACKETS**



**4 LEGS (A, B, C, D)**



**4 LEG RIB (A, B, C, D)**



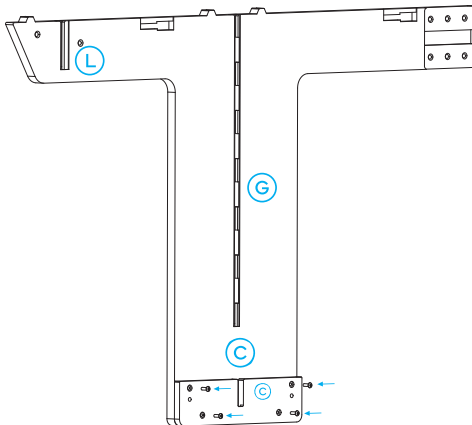
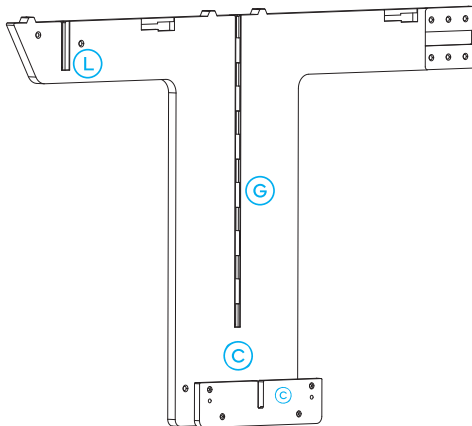
**2 CONNECTION TABS**



**4 DRAWER  
GUIDE**

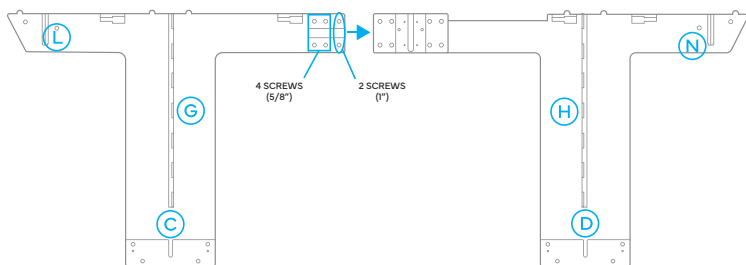
## STEP 1

Join the Leg G and Leg Rib C into a single unit using (4) 5/8". Repeat this process for Leg E, Leg F and Leg H.  
(Refer to the letter system in the images for alignment.)



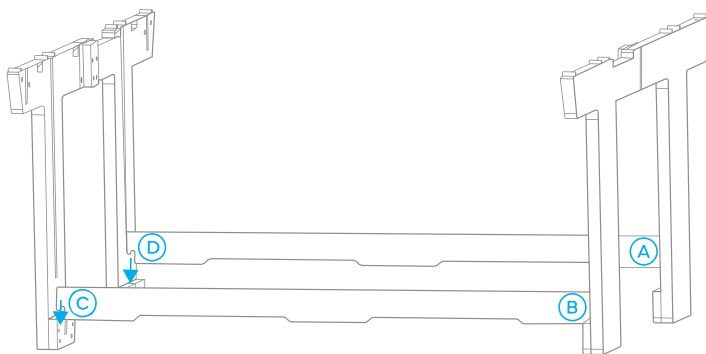
## STEP 2

Join the assembled Leg G and Leg H into a single unit using (4) 5/8" screws and (2) x 1" screws. Repeat this process for Leg E and Leg F. (Refer to the letter system in the images for alignment.)



## STEP 3

Align the slots on the bottom boards with the corresponding table legs. Match the lettered indicators, ensuring the letter system faces the inside of the table. Slide the components together, using a rubber mallet if necessary OR until all four pieces are fully seated. (see image).



#### STEP 4

Find and Insert the (8) small keys into the designated T-slots (see image 1). Align the shelves by matching the corresponding lettered indicators. Ensure all keys are pre-installed before lowering the shelves into position (see image 2). Secure each corner using the provided 5/8" screws.

IMAGE 1

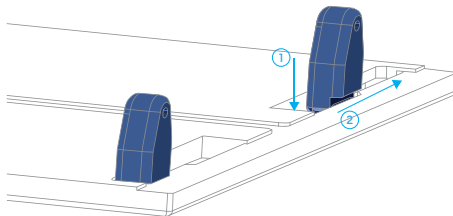
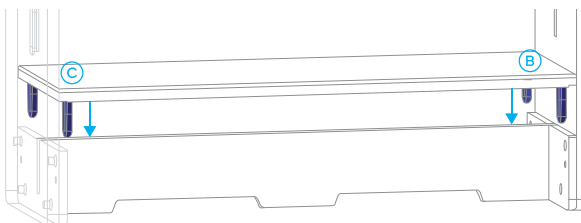


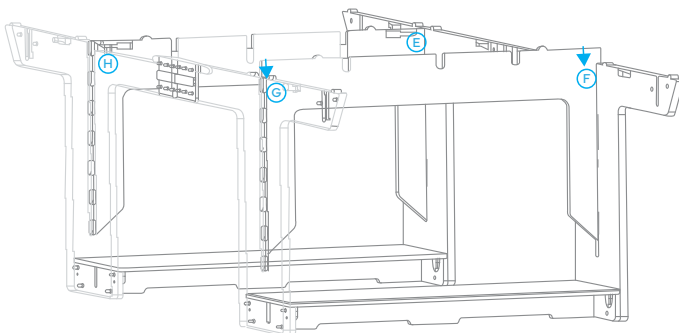
IMAGE 2



#### STEP 5

Align the two brackets marked G and insert them into the table leg. Slide the components together until fully seated.

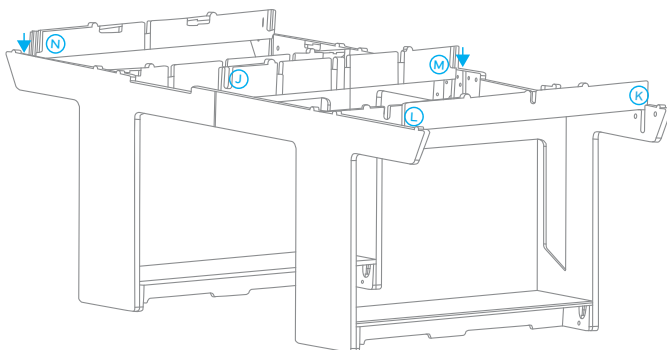
**Tip:** If the fit is tight, a rubber mallet or a small amount of soapy water can be used to assist (see final page of guide). Repeat this process for legs E and F.



## STEP 6

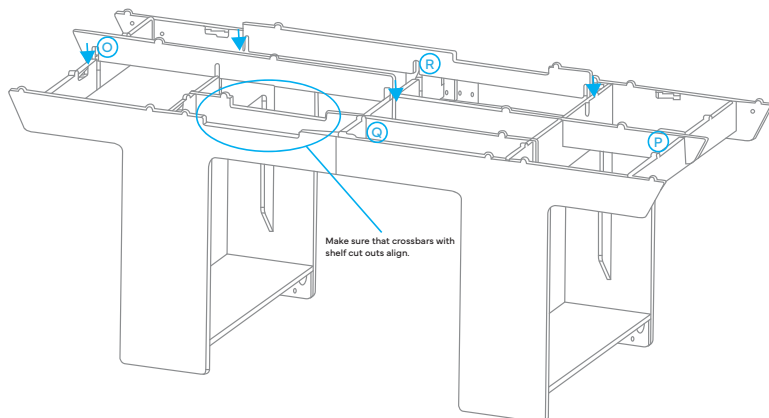
Align the lettered indicators on the top crossbars with the corresponding table legs. Slide the components together until the top surfaces are completely flush (see image).

**Note:** If the fit is tight, a rubber mallet or soapy water can be used to assist (see final page of guide). Repeat this process for all three crossbars.



## STEP 7

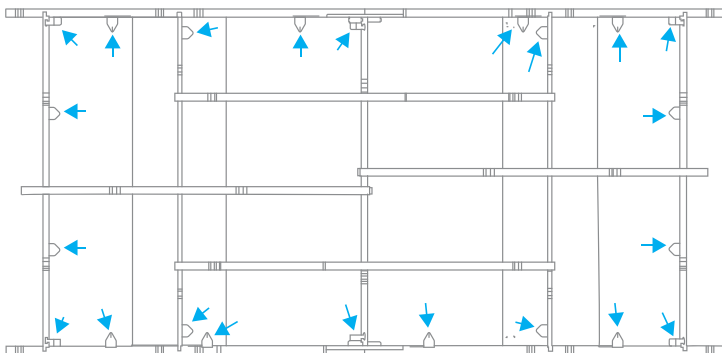
Align the lettered indicators on the four perpendicular crossbars and insert them into the table frame. Slide the components together until the top of the crossbars sit flush with the frame (see image).



## STEP 8

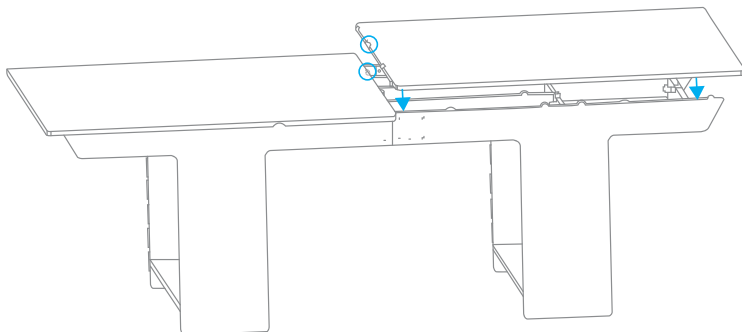
Insert the (22) large keys into the designated key slots on the brackets.

**Note:** Do not fasten or screw the keys into place until Step 9.



## STEP 9

Position the tabletop onto the frame with the grooves facing toward the center. Adjust the panel until the bottom grooves align with the frame and the tabletop drops securely into place. Repeat this process for the second tabletop (see image).



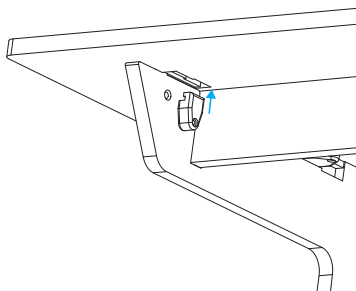
### STEP 10A

Locate the (22) keys previously inserted into the table. Secure them into place using the provided 1" screws and screw driver. (22 screws total).

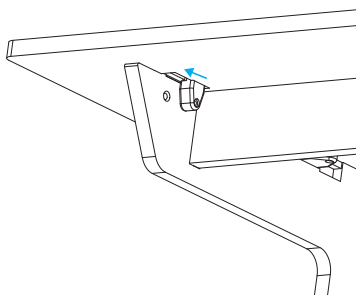
### STEP 10B

Secure the medium keys by installing one 1" screw into each corner. Use the provided screw driver to tighten all four screws until secure.

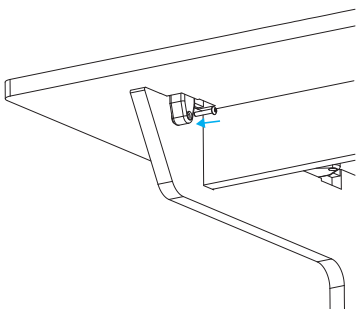
**IMAGE 1**



**IMAGE 2**

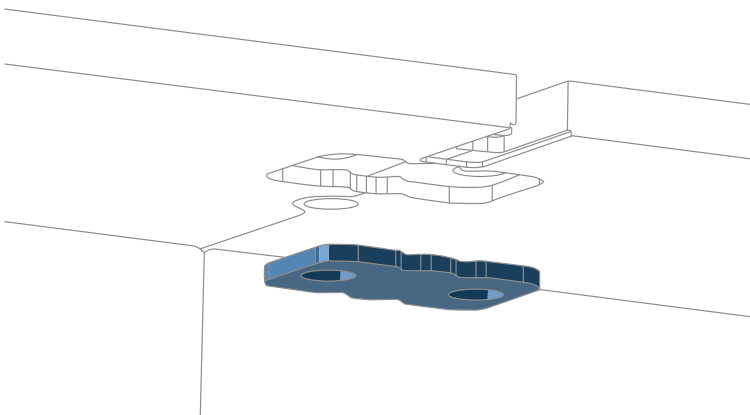


**IMAGE 3**



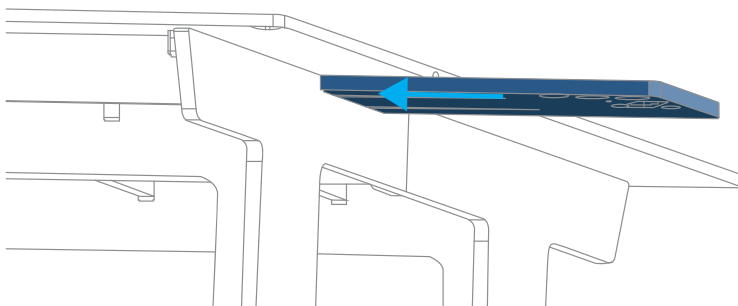
### STEP 11

Join the two tabletop sections using the (2) connection tabs. Secure with the provided 3/8" screws, being careful not to overtighten.



### STEP 12

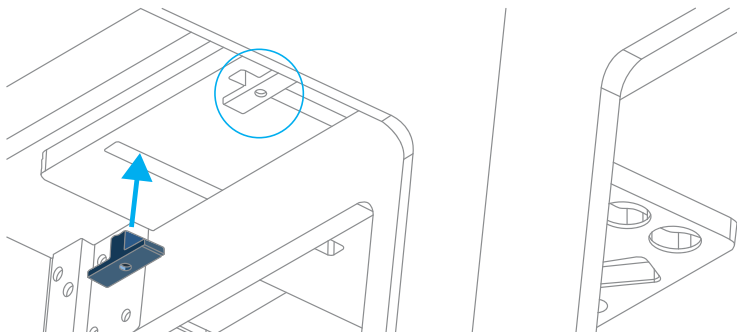
Slide the (2) paddle and ball drawers into their designated tracks until fully seated.



### STEP 13A

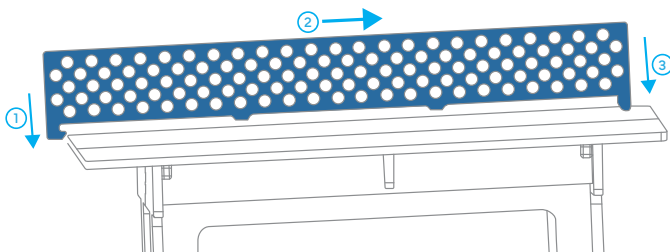
Secure the drawer using the (2) T-shaped keys and the provided 1" screws. Repeat this process for the second drawer.

**Tip & Trick:** Do not over tighten the T shaped keys to allow drawer to slide smoothly.



### STEP 13B

Slide the side of the net with the hook tab into the designated notch on the tabletop. Press down firmly on the opposite side until it locks securely into place.



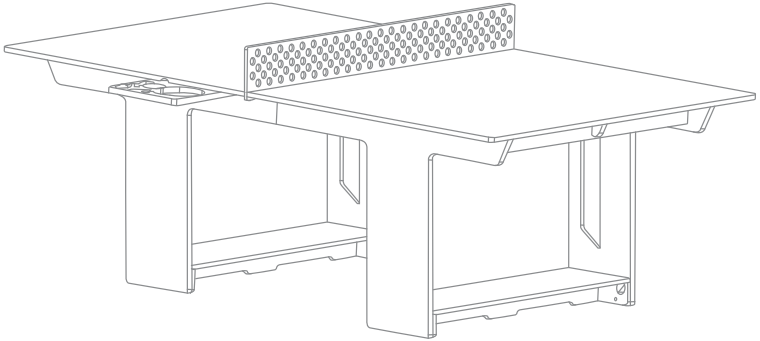
### STEP 14

**Optional:** For added stability, secure the net to the tabletop using the provided 1" screw.

## STEP 15

### Assembly Complete

We hope your new piece serves as the backdrop for life's most meaningful moments. We would love to see how you've styled your space, tag us [@ledgelounger](#) for a chance to be featured in our gallery!



## CARE AND MAINTENANCE

### ROUTINE CLEANING

For everyday upkeep, wipe the surface with a soft cloth or microfiber towel, or simply rinse with a garden hose. For a deeper clean, use a mild soap and water solution with a soft-bristle brush to remove stubborn debris.

### POWER WASHING

Exercise extreme caution when power washing to avoid etching or damaging the surface.

- **Initial Test:** Start with a low-PSI setting at a distance of at least 3 feet. Test an area on the underside of the product before proceeding.
- **Adjustment:** Gradually decrease the distance and increase pressure only as needed to remove dirt.
- **Final Check:** Inspect the surface frequently to ensure the spray pattern is not leaving permanent marks or lines on the material.

### SURFACE PREPARATION

For the best results and easiest assembly, ensure you are working on a flat, stable, and level surface. This prevents the frame from twisting and ensures all parts align perfectly.

### DRAWER INSTALLATION

**Do not over-tighten the hardware on the drawers.** Tighten until snug; excessive force can hinder the smooth operation of the sliding mechanism or damage the tracks.

### EASE OF ASSEMBLY

If you encounter a tight fit between components:

- **Lubrication:** Apply a small amount of soapy water to the joints to help parts slide smoothly into position.
- **Mechanical Assist:** If the pieces are still snug, use a rubber mallet to gently tap the components until they are fully seated and secure.



For a PDF version of these instructions, please scan the QR code.



Para instrucciones en español, por favor escanea este código QR.



Pour des instructions en français, veuillez scanner ce code QR.